

5XT COAXIAL ENCLOSURE

RIGGING MANUAL

VERSION 1.0

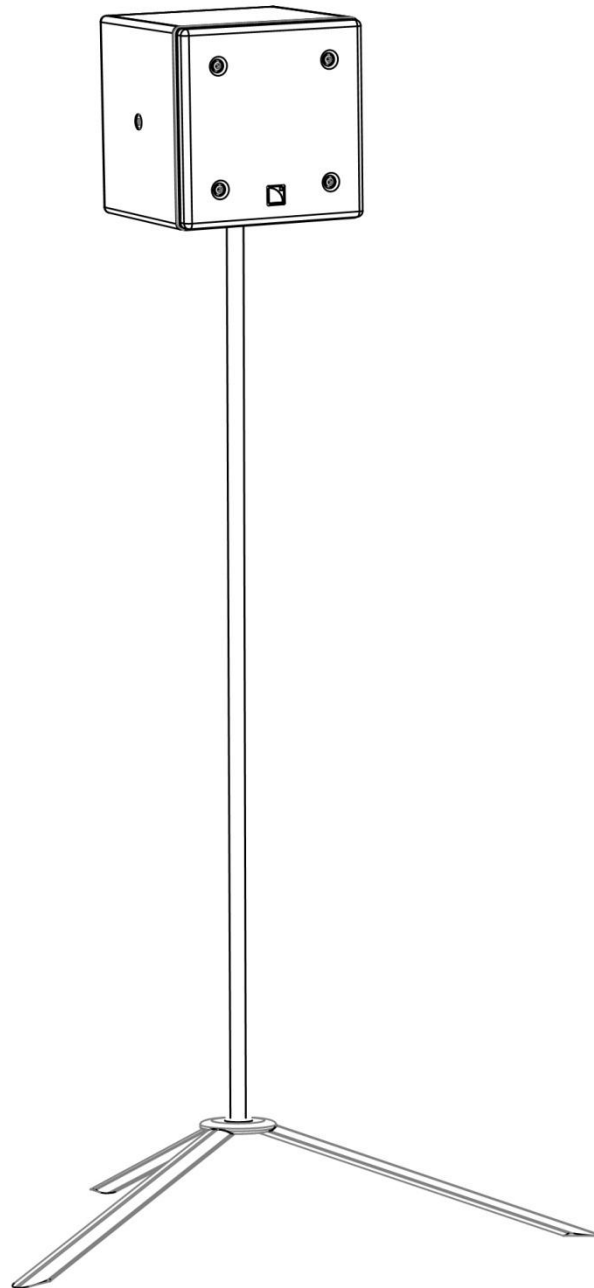
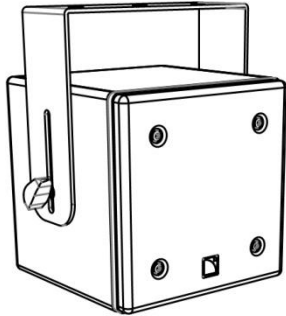

SAFETY INSTRUCTIONS

1. Read this manual

Heed all SAFETY INSTRUCTIONS as well as DANGER and OBLIGATION warnings

2. Never incorporate equipment or accessories not approved by L-ACOUSTICS®

3. Read all the related PRODUCT INFORMATION documents before exploiting the system

The product information document is included in the shipping carton of the related system component.

4. Work with qualified personnel for rigging the system

Installation should only be carried out by qualified personnel that are familiar with the rigging techniques and safety recommendations outlined in this manual.

5. Ensure personnel health and safety

During installation and set-up personnel must wear protective headgear and footwear at all times. Under no circumstances personnel is allowed to climb on a loudspeaker assembly.

6. Respect the Working Load Limit (WLL) of third party equipment

L-ACOUSTICS® is not responsible for any rigging equipment and accessories provided by third party manufacturers. Verify that the Working Load Limit (WLL) of the suspension points, chain hoists and all additional hardware rigging accessories is respected.

7. Respect the maximum configurations and the recommended safety level

For safety issue, respect the maximum configurations outlined in this manual. To check the conformity of any configuration in regards with the safety level recommended by L-ACOUSTICS®, model the system in SOUNDVISION and refer to the warnings in **Mechanical Data** section.

8. Be cautious when flying a loudspeaker array

Always verify that no one is standing underneath the loudspeaker array when it is being raised. As the array is being raised, check each individual element to make sure that it is securely fastened to the adjacent element. Never leave the array unattended during the installation process. As a general rule, L-ACOUSTICS® recommends the use of safety slings at all times.

9. Be cautious when ground-stacking a loudspeaker array

Do not stack the loudspeaker array on unstable ground or surface. If the array is stacked on a structure, platform, or stage, always check that the latter can support the total weight of the array. As a general rule, L-ACOUSTICS® recommends the use of safety straps at all times.

10. Take into account the wind effects on dynamic load

When a loudspeaker assembly is deployed in an open air environment, wind can produce dynamic stress to the rigging components and suspension points. If the wind force exceeds 6 bft (Beaufort scale), lower down and/or secure the loudspeaker array.

SYMBOLS

The following symbols are used in this document:



DANGER

This symbol indicates a potential risk of harm to an individual or damage to the product. It can also notify the user about instructions that must be strictly followed to ensure safe installation or operation of the product.



OBLIGATION

This symbol notifies the user about instructions that must be strictly followed to ensure proper installation or operation of the product.



INFORMATION

This symbol notifies the user about complementary information or optional instructions.



WELCOME TO L-ACOUSTICS®

Thank you for choosing the L-ACOUSTICS® 5XT coaxial enclosure.

This document contains essential information on rigging the system properly and safely. Carefully read this document in order to become familiar with these procedures.

As part of a continuous evolution of techniques and standards, L-ACOUSTICS® reserves the right to change the specifications of its products and the content of its documents without prior notice.

Please check the L-ACOUSTICS® web site on a regular basis to download the latest document and software updates: www.l-acoustics.com.

CONTENTS

1	RIGGING SYSTEM	4
1.1	Loudspeaker enclosure	4
1.2	Rigging elements.....	4
1.3	Software application.....	4
2	MECHANICAL SAFETY	5
2.1	Maximum configurations	5
2.2	Assessing mechanical safety.....	5
3	SYSTEM SETUP	6
3.1	Flying.....	6
3.2	Pole-mounting.....	6
4	SUBSET PROCEDURES	7
PROCEDURE A	Attaching the ETR5 on the 5XT	7
APPENDIX A:	ETR5 STORAGE POSITION	9
APPENDIX B:	5XT AND ETR5 DIMENSIONS	10

5XT COAXIAL ENCLOSURE

RIGGING MANUAL

VERSION 1.0

1 RIGGING SYSTEM

The system approach developed by L-ACOUSTICS® consists in providing packaged solutions for loudspeaker systems in order to guarantee the highest and most predictable level of performance at any step: modeling, installation, and operation. An L-ACOUSTICS® loudspeaker system is the set of components available to form any loudspeaker system based on one of the full-range loudspeaker enclosures afforded by L-ACOUSTICS®. It includes enclosures, rigging accessories, loudspeaker cables, amplified controllers and software applications.

The main components involved in the **5XT** rigging process are the following:

1.1 Loudspeaker enclosure

5XT Coaxial enclosure.
Equipped with 2 × M6 and 1 × 3/8 microphone-stand insert.



Loudspeaker system design

Sound design aspects are beyond the scope of this document. However, the various applications of the system will be based on the operating modes presented in this document.

1.2 Rigging elements

ETR5 U-bracket used to fly the 5XT.

1.3 Software application

SOUNDVISION Proprietary 3D acoustical and mechanical modeling software.



Other 5XT SYSTEM components

All the other components of the system are presented in the 5XT **user manual**, document intended to describe the enclosures operation and connection.



5XT

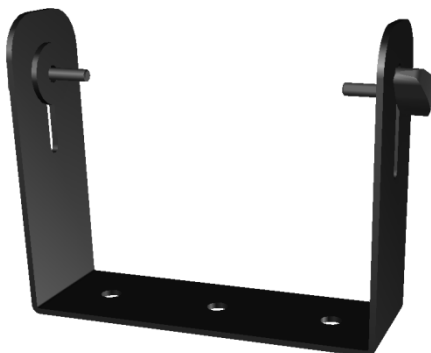

ETR5

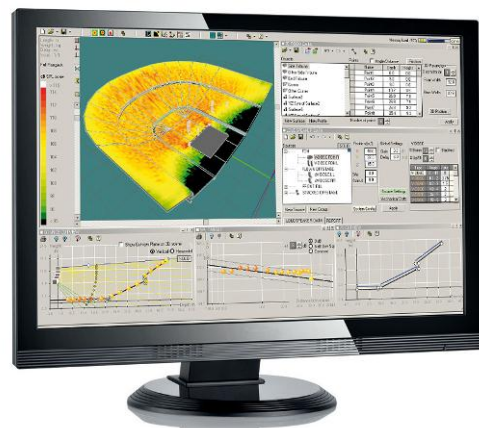

SOUNDVISION

Main components involved in the 5XT rigging process

2 MECHANICAL SAFETY

2.1 Maximum configurations

The 5XT rigging system complies with BGV-C1 (2012), DIN 18800 and EN ISO 12100-1 (2004) when SOUNDVISION software does not indicate any *stress warning*.



Mechanical safety of the rigging system

Before any installation, always model the system in SOUNDVISION and check the **Mechanical Data** section for any *stress warning* or *stability warning*.

2.2 Assessing mechanical safety

In order to assess the actual safety of any array configuration before implementation, refer to the following warnings:



Rated working load limit (WLL) is not enough

The rated WLL is an indication of the element resistance to tensile stress. For complex mechanical systems such as loudspeaker arrays, WLLs cannot be used per se to determine the maximum number of enclosures within an array or to assess the safety of a specific array configuration.



Mechanical modeling with SOUNDVISION

The working load applied to each linking point, along with the corresponding safety factor, will depend on numerous variables linked to the composition of the array (type and number of enclosures, splay angles) and the implementation of the flying or stacking structure (number and location of flying points, site angle). This cannot be determined without the complex mechanical modeling and calculation offered by SOUNDVISION



Assessing the safety with SOUNDVISION

The overall safety factor of a specific mechanical configuration always corresponds to the lowest safety factor among all the linking points. Always model the system configuration with the SOUNDVISION software and check the Mechanical Data section to identify the weakest link and its corresponding working load. By default, a *stress warning* will appear when the mechanical safety goes beyond the recommended safety level.



Safety of ground-stacked arrays in SOUNDVISION

For ground-stacked arrays, a distinct *stability warning* is implemented in SOUNDVISION. It indicates a tipping hazard when the array is not secured to the ground, stage or platform. It is user responsibility to secure the array and to ignore this warning.



Consideration must be given to unusual conditions

SOUNDVISION calculations are based on usual environmental conditions. A higher safety factor is recommended with factors such as extreme high or low temperatures, strong wind, prolonged exposition to salt water, etc. Always consult a rigging specialist to adopt safety practices adapted to such a situation.

5XT COAXIAL ENCLOSURE

RIGGING MANUAL

VERSION 1.0

3 SYSTEM SETUP



Dismantling

Apply the associated setup procedure in reversed order.

3.1 Flying

The 5XT has an M6 insert on each side of the cabinet to attach the ETR5.

The ETR5 has three Ø11 mm holes at the top. If needed, use Ø10 mm screws to attach it.



Tools

Electric screwdriver with torque selector.
T30 bit.

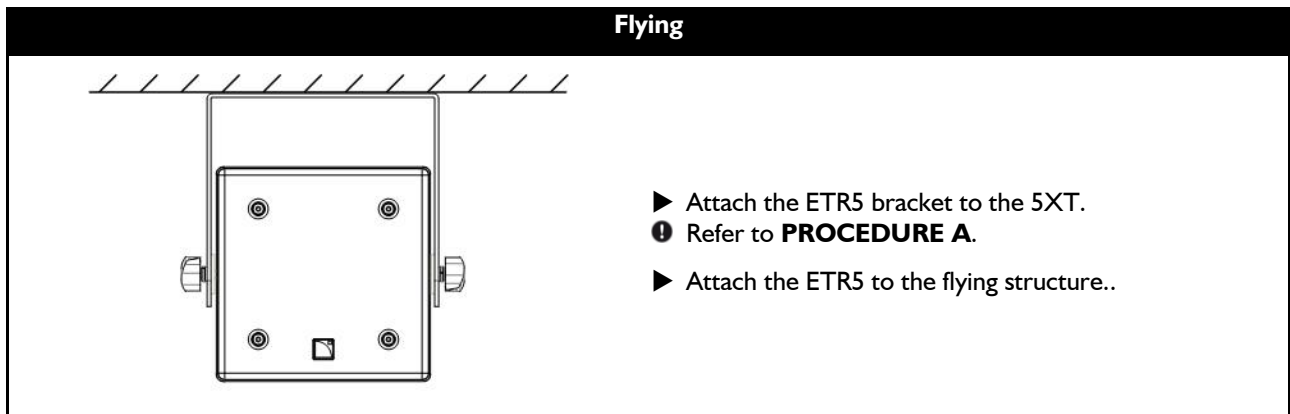

3.2 Pole-mounting

The 5XT has a 3/8" insert on the bottom side of the cabinet to mount the enclosure on a European microphone-stand.

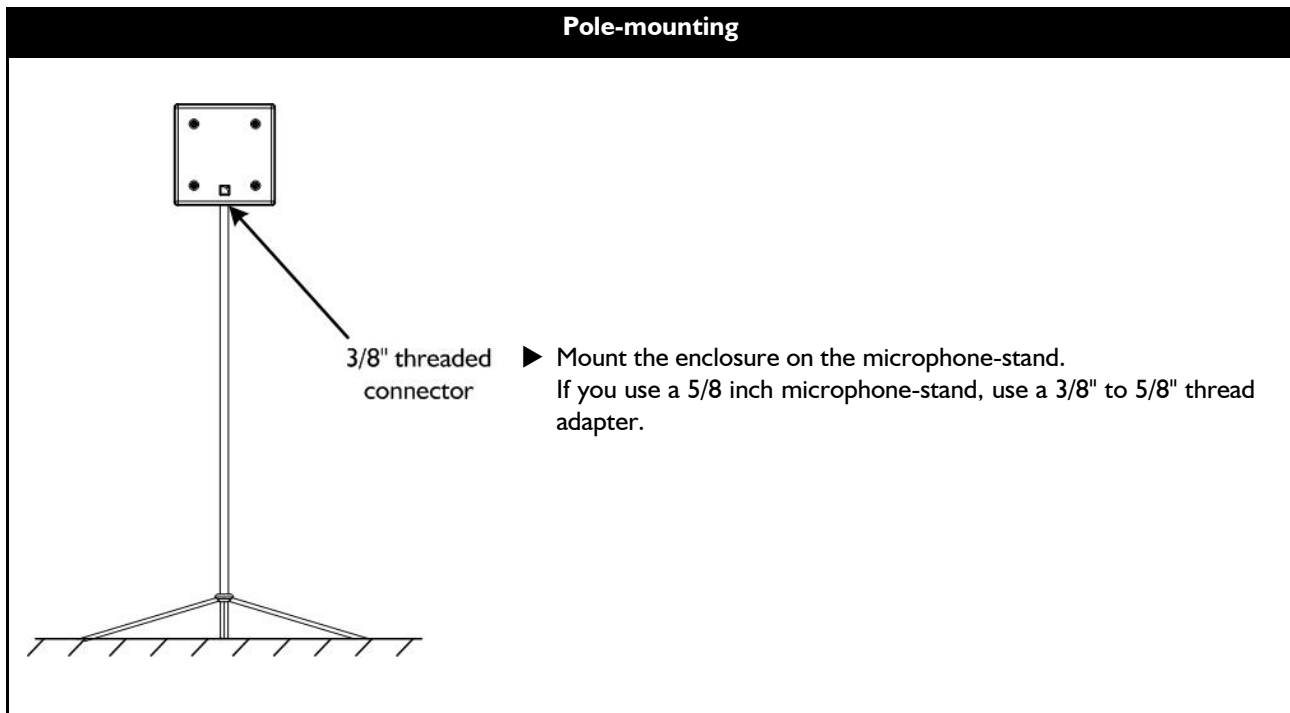

4 SUBSET PROCEDURES

PROCEDURE A Attaching the ETR5 on the 5XT



Tools

Electric screwdriver with torque selector.
T30 bit.

1. Remove the screw from the insert on both sides of the enclosure.
Use a T30 bit.
2. Slide the metal washers on the knobs in this order:
plain washer | Grower washer | plain washer.
3. Attach the bracket to the enclosure.
 - a. Position the bracket.
 - b. On one side, slide the rubber washer between the bracket and the cabinet.
 - c. Align the washer, the bracket slot and the insert, and start inserting the knob.
 - d. Repeat the steps b. and c. on the other side of the enclosure.
4. Set the bracket to its final position.
 - a. Adjust the bracket angle and height.
 - b. Tighten the knobs to secure the bracket.

5XT COAXIAL ENCLOSURE

RIGGING MANUAL

VERSION 1.0



Tools

Electric screwdriver with torque selector.
T30 bit.

► PROCEDURE A

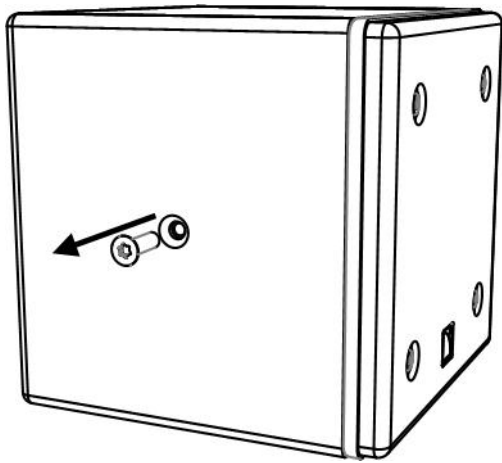

1.

Removing the screw.

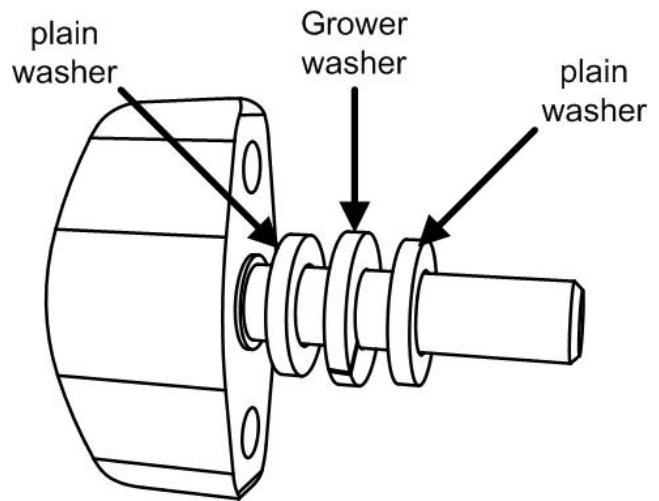

2.

Order of the washers.

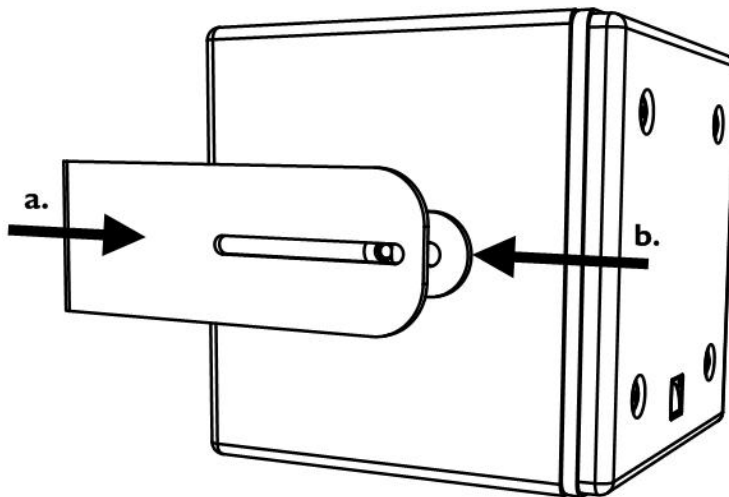

3.

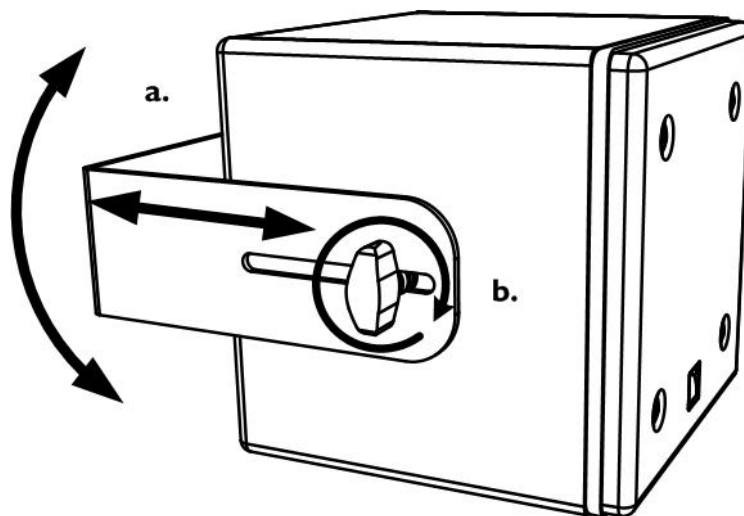

4.

Adjusting the angle and height and tightening the knobs.

APPENDIX A: ETR5 STORAGE POSITION

When the 5XT is stored the ETR5 can be used to protect the connectors at the back of the enclosure as illustrated below.

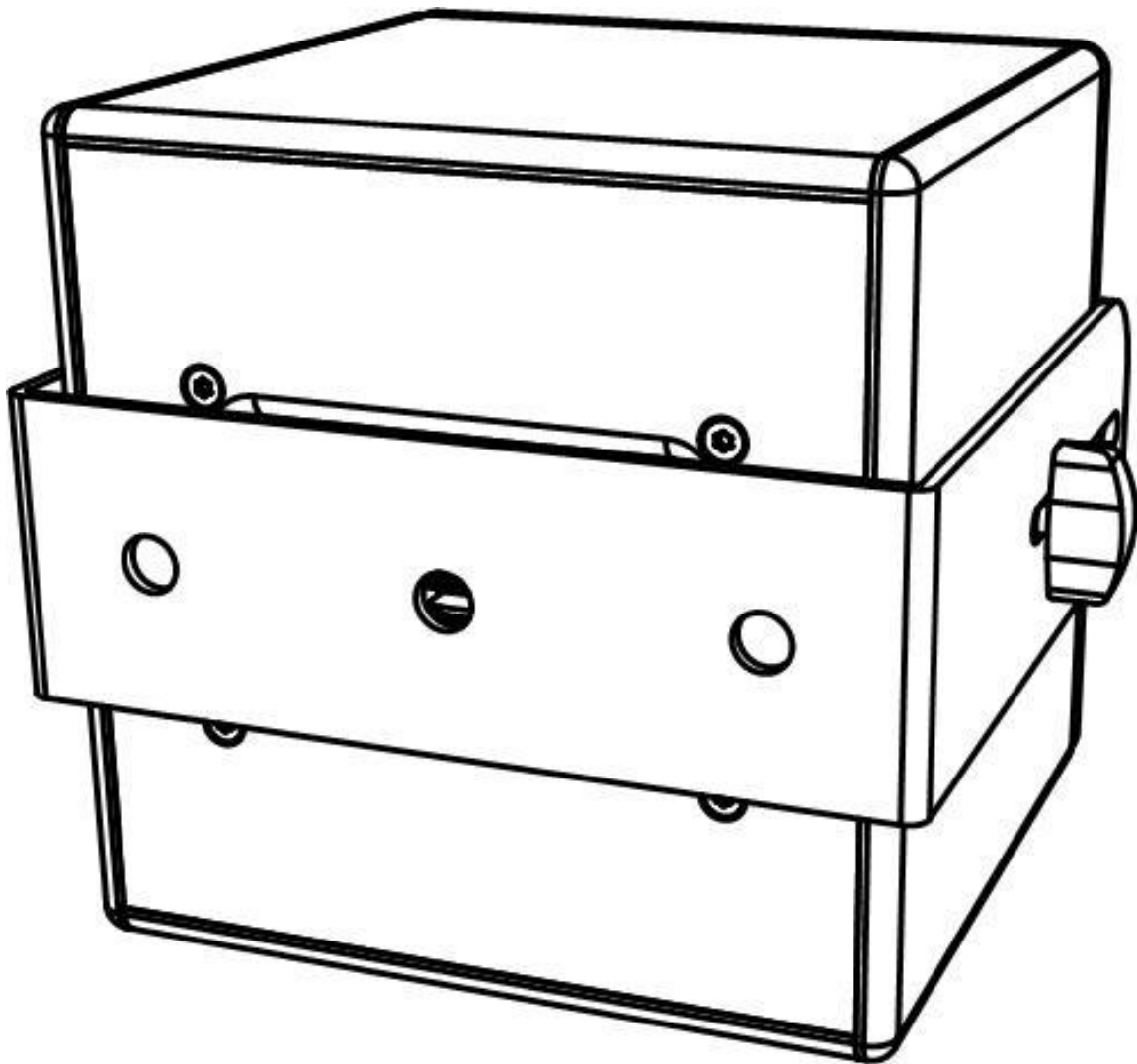

5XT COAXIAL ENCLOSURE

RIGGING MANUAL

VERSION 1.0

APPENDIX B: 5XT AND ETR5 WEIGHT AND DIMENSIONS

5XT

3.5 kg / 7.7 lb

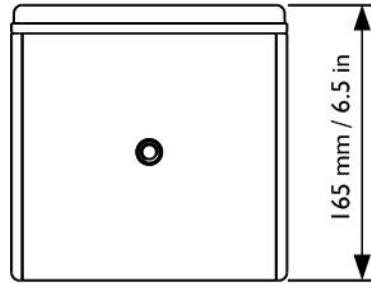

BOTTOM

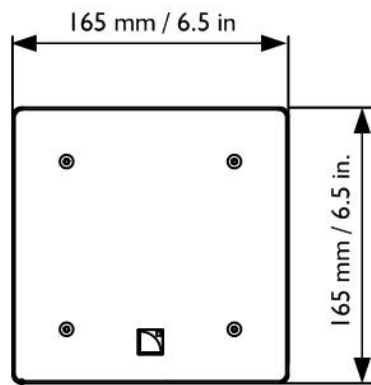

FRONT

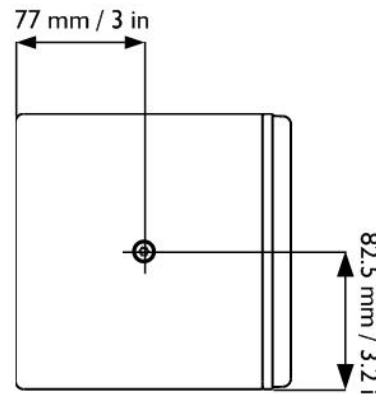

SIDES

ETR5

0.7 Kg / 1.55 lb

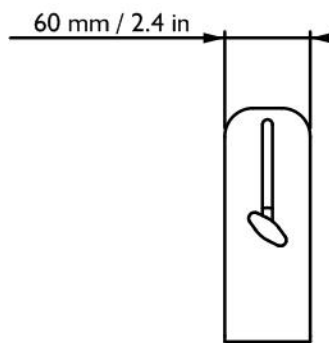

SIDES

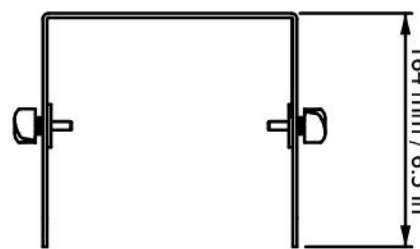

FRONT

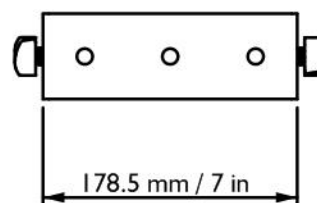

TOP



Document reference: 5XT_RM_EN_1.0

Distribution date: November 23, 2012

© 2012 L-ACOUSTICS®. All rights reserved.

**No part of this publication may be reproduced or transmitted in any form
or by any means without the express written consent of the publisher.**