

MicroCue²

User Manual



Cueing and Presentation Control Specialists

Contents:

Introduction	3
Safety Instructions	4
Diagrams	5
Regulations Compliance	6
Operating Instructions	10
Programming Special Cues	12
Special Requirements	14
Radio Frequency System	14
Equipment Supplied	15
Technical Support Contact	15

Introduction

MicroCue² is the mobile professional's 1st choice presentation cueing system. Featuring USB interfacing, MicroCue² can connect to computers and directly control up to 2 PowerPoint presentations as in main and back up or a separate presentation for notes etc., as well as providing visual and audible cues. The system design provides for a highly portable and a quick, easy-to-set-up presentation control system.

MicroCue² is based on the Interspace Industries MasterCue series platform, retaining proven features such as the robust case design and the AV industrial grade wireless RF system.

With 3 buttons the presenter can request to go backwards as well as forwards if required, or to communicate an alternative presentation function (e.g. go to black or restart). The visual and audible cues are easy to understand and designed to clearly indicate which button has been pushed and what cue action is required.

MicroCue² ***- For Professional Presentations on the Move!***

We hope MicroCue² exceeds your expectations and welcome any feedback that you have about this or any of our products.

Thank you.

The Interspace Industries Team
www.interspaceind.com

Safety Instructions

All safety and operating instructions should be read before this product is operated and should be retained for further reference. Please adhere to all the warnings on this product and in these operating instructions. Please follow these instructions carefully.

Power. Only use the power source indicated on the device. Devices equipped with a grounded plug should only be used with a grounded type outlet. In no way should this grounding be disconnected, modified or suppressed.

Power Supply Lead. To unplug the device always pull by the plug itself, not the power supply lead. The power source outlet should always be near the MicroCue main unit and easily accessible. Ensure the power supply lead cannot be walked on or damaged by items placed on or against it. **Do not use if the power supply lead is damaged.** Using the device with a damaged power supply lead may expose you to electric shock or other hazards. Check the condition of the power supply lead regularly. Contact your dealer or service centre immediately for a replacement if damaged.

Keep Away From Harmful Substances

To prevent the risk of electric shock and fire, do not expose this device to rain, humidity or intense heat sources (such as radiators or direct sunlight). Avoid using this equipment in environments where there is excessive heat, dust, moisture, chemicals, vibration or mechanical shocks.

Slots and Openings. These are designed into the device for ventilation and to avoid overheating. Always ensure these openings remain clear. **Do not attempt to insert anything into these openings under any circumstances.** If liquids have been spilled on, or objects have fallen into the product it must be checked by a qualified technician before re-using.

Connections. All inputs and outputs (except for power input) are TBTS defined under EN60950.

- **DO NOT OPEN SYSTEM DUE TO HIGH VOLTAGE.**
- **DO NOT IMMERSE IN WATER.**

If you have any queries regarding these safety instructions or how to maintain the unit please do not hesitate to contact us on:

+44(0)870 770 8088

Servicing. Do not attempt to service this product yourself. Opening or removing covers and screws may expose you to electric shocks or other hazards. Refer all servicing to qualified service personnel.

Diagrams

Figure 1 MicroCue Connections Diagram

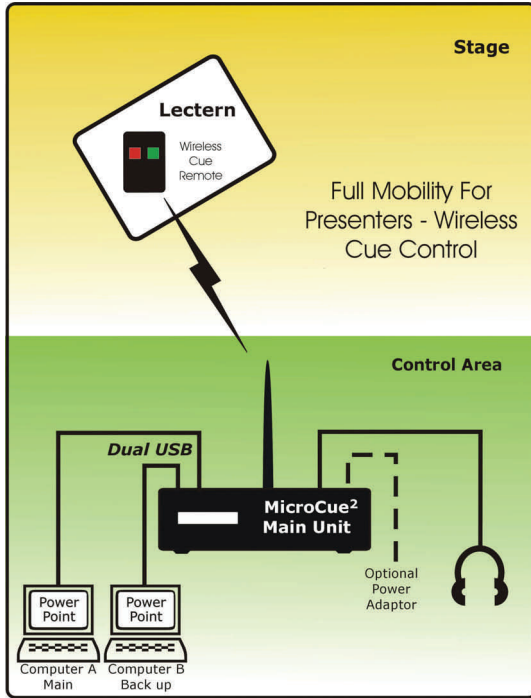
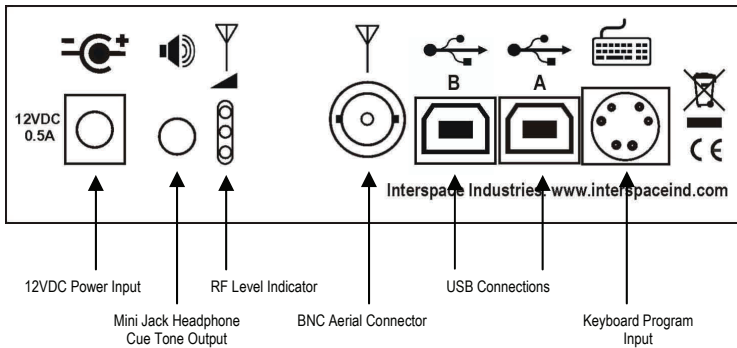

Figure 2 MicroCue Rear Panel



FCC STATEMENTS

Interspace Industries

MicroCue

Made In UK.

This device complies with Part 15 of the FCC Rules. Operation is subject to the following two conditions:

(1) This device may not cause harmful interference, and (2) this device must accept any interference received, including interference that may cause undesired operation.

Interspace Industries
28 High Street
Arlesey
SG15 6RA
UK

+44 870 770 8088 : Out of hours +44 7976 385 046

Warning ! Any modification or changes made to this device, unless explicitly approved by Company name, will invalidate the authorisation of this device. Operation of an unauthorised device is prohibited under Section 302 of the Communications Act of 1934, as amended, and Subpart I of Part 2 of Chapter 47 of the Code of Federal Regulations.

NOTE: This equipment has been tested and found to comply with the limits for a Class B digital device, pursuant to Part 15 of the FCC Rules. These limits are designed to provide reasonable protection against harmful interference in a residential installation. This equipment generates, uses and can radiate radio frequency energy and, if not installed and used in accordance with the instructions, may cause harmful interference to radio communications. However, there is no guarantee that interference will not occur in a particular installation. If this equipment does cause harmful interference to radio or television reception, which can be determined by turning the equipment off and on, the user is encouraged to try to correct the interference by one or more of the following measures:

- Reorient or relocate the receiving antenna.
- Increase the separation between the equipment and receiver.
- Connect the equipment into an outlet on a circuit different from that to which the receiver is connected.
- Consult the dealer or an experienced radio/TV technician for help.

FCC COMPLIANCE INFORMATION STATEMENT DECLARATION OF CONFORMITY

Manufacturer:	Interspace Industries
Responsible Party in the USA:	Interspace Industries 28 High Street, Arlesey SG15 6RA, UK Tel Office: 0044 870 770 8088 Out of Hours: 0044 7976 385 046
Product:	MicroCue
Authorisation Procedure:	Declaration of Conformity

This device complies with Part 15 of the FCC Rules. Operation is subject to the following two conditions: (1) this device may not cause harmful interference, and (2) this device must accept any interference received, including interference that may cause undesired operation.

We, Interspace Industries, have determined that the above named equipment has been shown to comply with the applicable technical standards. Furthermore, we warrant that each unit of equipment marketed is identical to the unit tested and found acceptable with the standards. The records maintained continue to reflect the equipment being produced within the variation that can be expected due to quantity production and testing on a statistical basis.

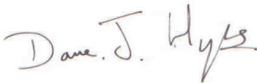

David J Humphrys, Managing Director
Interspace Industries
28 High Street
Arlesey
Bedfordshire SG15 6RA
UK

2nd March 2006

EC DECLARATION OF CONFORMITY TO R&TTE DIRECTIVE 1995/5/EC

Manufacturer:	Hive Industries Ltd
Product:	MicroCue
Conformity Assessment:	Annex III; Internal production control plus specific apparatus tests

Reference standards used for presumption of conformity:

Article 3.1a EN 60950-1:2001, A11

Article 3.1b EN 301 489-3 v1.4.1.

Article 3.2 EN 300 220-3 v1.1.1.

Declaration

We, Interspace Industries, declare under our sole responsibility that the essential radio test suites have been carried out and that the above product to which this declaration relates is in conformity with all the applicable essential requirements of EU Directive 1995/5/EC

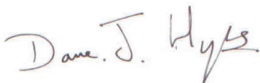

David J Humphrys, Managing Director
Interspace Industries
28 High Street
Arlesey
Bedfordshire SG15 6RA
UK

2nd March 2006

EC DECLARATION OF CONFORMITY TO R&TTE DIRECTIVE 1995/5/EC

English	Hereby, Interspace Industries, declares that this "MicroCue" is in compliance with the essential requirements and other relevant provisions of Directive 1999/5/EC.
Finnish	Interspace Industries vakuuttaa täten että "MicroCue" tyypinen laite on direktiivin 1999/5/EY oleellisten vaatimusten ja sitä koskevien direktiivin muiden ehtojen mukainen.
Swedish	Härmed intygar Interspace Industries att denna "MicroCue" står i överensstämmelse med de väsentliga egenskapskrav och övriga relevanta bestämmelser som framgår av direktiv 1999/5/EG.

Danish	Undertegnede Interspace industries erklærer herved, at følgende udstyr "MicroCue" overholder de væsentlige krav og øvrige relevante krav i direktiv 1999/5/EF
Dutch	Hierbij verklaart Interspace industries dat het toestel "MicroCue" in overeenstemming is met de essentiële eisen en de andere relevante bepalingen van richtlijn 1999/5/EG
	Bij deze verklaart Interspace industries dat deze "MicroCue" voldoet aan de essentiële eisen en aan de overige relevante bepalingen van Richtlijn 1999/5/EC.
French	Par la présente Interspace Industries déclare que l'appareil "MicroCue" est conforme aux exigences essentielles et aux autres dispositions pertinentes de la directive 1999/5/CE
	Par la présente, Interspace Industries déclare que ce "MicroCue" est conforme aux exigences essentielles et aux autres dispositions de la directive 1999/5/CE qui lui sont applicables
German	Hiermit erklärt Interspace Industries, dass sich dieser/diese/dieses "MicroCue" in Übereinstimmung mit den grundlegenden Anforderungen und den anderen relevanten Vorschriften der Richtlinie 1999/5/EG befindet". (BMW)
	Hiermit erklärt Interspace Industries die Übereinstimmung des Gerätes "MicroCue" mit den grundlegenden Anforderungen und den anderen relevanten Festlegungen der Richtlinie 1999/5/EG. (Wien)
Greek	ΜΕ ΤΗΝ ΠΑΡΟΥΣΑ Interspace Industries ΔΗΛΩΝΕΙ ΟΤΙ "MicroCue" ΣΥΜΜΟΡΦΩΝΕΤΑΙ ΠΡΟΣ ΤΙΣ ΟΥΣΙΩΔΕΙΣ ΑΠΑΙΤΗΣΕΙΣ ΚΑΙ ΤΙΣ ΛΟΙΠΕΣ ΣΧΕΤΙΚΕΣ ΔΙΑΤΑΞΕΙΣ ΤΗΣ ΟΔΗΓΙΑΣ 1999/5/ΕΚ
Italian	Con la presente Interspace Industries dichiara che questo "MicroCue" è conforme ai requisiti essenziali ed alle altre disposizioni pertinenti stabilite dalla direttiva 1999/5/CE.
Spanish	Por medio de la presente Interspace Industries declara que el "MicroCue" cumple con los requisitos esenciales y cualesquiera otras disposiciones aplicables o exigibles de la Directiva 1999/5/CE
Portuguese	Interspace Industries declara que este "MicroCue" está conforme com os requisitos essenciais e outras disposições da Directiva 1999/5/CE.

Environmental

WEEE and RoHS Compliance. MicroCue² and its associated accessories have been manufactured and sold in accordance with the requirements of the EC WEEE and RoHS directives. Please return all end-of-life items to your supplier, or Interspace Industries directly, for appropriate disposal.

Packaging Materials:

Cardboard box: Grade 150 K/T 'B' (Single Walled Corrugated - Brown Kraft)
Protective Foam: Grade HLB 22 Grey Foam (High Load Bearing)

Electrical

CE Mark. MicroCue and its associated accessories have been designed, manufactured and certified to comply with all requirements of the European CE standard.

Operating Instructions

Unpacking and Connections. Unpack the main unit and place on a flat surface within easy access for the Operator (see figure 1). Connect the aerial to the BNC connector on the rear of the main unit (see figure 2) and position so the aerial is vertical.

Power and Start up. MicroCue² can be powered using either the USB connection to a computer or an optional 12VDC power pack (part number: PSU). After connecting either power source to the main unit the system will do a short test, during which the display on the main unit will flash green once, then red once. The presenter control selector button will remain on to show that the system is working correctly and both USB ports are enabled if computers are connected.

RF Signal Strength. A Green LED RF level indicator on the rear of the main unit (see figure 2) displays the RF signal strength of the handset when any cue button is pressed. If any of the RF level indicator LEDs remain on between cues from the handset then this is back-ground RF signal interference which could reduce the performance of MicroCue². Try repositioning the main unit away from electrical/electronic equipment to reduce this as much as possible.

Basic Operation. Check the system by momentarily pressing any of the handset buttons to give a cue. The display on the main unit will strobe green if the 'NEXT' (green) button is pressed and red if the 'BACK' (red) button is pressed. Pressing the BLACK button will cause the display to go fixed red to show it is in a Black, paused state. Pushing any button will cause it to come out of Black/Paused mode only.

If the system does not give cue signals when any of the handset buttons are pressed, check the RF level indicator on the rear of the MicroCue main unit (see figure 2). If this shows a signal is being received, this confirms the handset code needs to be 'learned' by MicroCue² (see 'Learning Handsets' Section).

Handset Timeout. To ensure maximum battery life and to comply with international Radio Frequency regulations, the handset will only transmit for a maximum of 5 seconds if any button is pressed and held down.

Headphone Connection. Plug a set of stereo headphones into the cue tone output socket on the rear of the main unit (see figure 2). Whilst pressing any cue button on the handset repeatedly at 1 second intervals, adjust the volume of the cue tones for a comfortable level, using a small flat screwdriver through the aperture underneath the main unit.

The cue tone audio output mini jack socket connections are as follows (mono out on stereo head phones):

Tip: Signal out
Ring: Ground
Sleeve: No-connection

Presenter Control Selector Mode. MicroCue² will start up in the default dual Control mode (A and B illuminated). In this mode and with MicroCue² connected to the computer via the USB port (see figure 2), the presenter can control their PowerPoint presentations on 2 computers directly from the handset. Pressing the front panel button will change to Operator Control mode (button not illuminated) and MicroCue will only signal cues via the visual display on the main unit and the cue tone audio output. Selecting the button again will enable USB "A," another press of the button will cycle to USB "B". A further push will enable both USB connectors together as at start up

NOTE: It is recommended that you always fully test Presenter Control mode with the computer thoroughly during rehearsals!

'Learning' the Handset. MicroCue² uses coded transmission data to identify each handset. This ensures that only those handsets programmed to each MicroCue² will be able to send cue signals, making it impossible for the system to receive false cue commands. Up to 16 handsets can be programmed to each MicroCue² main unit if required.

To learn the handset coding, momentarily press the 'Learn' button on the underside of the MicroCue² main unit using a suitable tool (e.g. a ball point pen or similar). The LED will illuminate to confirm the system is ready to learn a new handset. Press any button on the handset to send a cue signal to MicroCue². The LED will extinguish and the visual display on the front panel will confirm the cue has been received.

Handset Code Erase. To erase all handset learn codes, press and hold the 'Learn' button on the underside of the MicroCue² main unit using a suitable tool (e.g. a ball point pen or similar). Remain holding the 'Learn' button until the LED extinguishes. NOTE: This may take up to 20 Seconds. All handset codes will then be erased and MicroCue² will be unable to receive any cue commands at all.

System Reset. MicroCue² can be reset to all factory default settings - including any handset special cue commands. Whilst pressing the Presenter Control button on the front panel, momentarily press the 'Learn' button on the underside of the main unit using a suitable tool (e.g. a ballpoint pen or similar). The visual display on the front panel will turn green to confirm the reset and when the Presenter Control button is released the system will go through the normal start up routine.

NOTE: System reset does NOT erase the handset 'learn' coding.

Handset Battery. If no cue signals are received from the handset and the cue LED on the handset does not illuminate when any cue button is pressed, the battery will need to be replaced. Replace with 9V alkaline type MN1604 (6LR61.9V) only. To maximise battery life it is recommended that the battery be removed from the handset during any unsupervised shipping and if being stored un-used for long periods.

Programming Special Cues

The handset buttons are default programmed to simulate the keyboard commands → for NEXT, ← for BACK and the letter "b" for Black. These buttons can also be reprogrammed to send different keyboard commands to the computer running PowerPoint presentations if required. Some common alternative keyboard commands include:

- Keying the letter 'w' takes the screen to white
- Keying the letter 'b' takes the screen to black (default black button command)
- Keying any number then ←skips to that number slide in the presentation
- Keying '1' then ← resets the presentation to the 1st slide
- Keying the letters 'z', 'x', 'c' or 'v' have no effect during a PowerPoint presentation and programming any of these to a handset button will effectively disable that button on the handset if required.

To reprogram MicroCue², firstly ensure it is plugged into a computer using the USB cable supplied. Plug a computer keyboard with a PS2 connection into the PS2 socket on the rear panel of MicroCue² (see figure 2). Check the keyboard can control the computer by using keys as normal. Note that only the standard alpha-numeric keys will operate. The CTRL and FN keys will not operate whilst connected to MicroCue² in this way.

It can be helpful to have PowerPoint running on the computer during programming although this is not essential.

Press and hold the Presenter Control button on the front panel of MicroCue. After about 6 seconds the visual display will cycle through the three handset button programming points:

- Green only on the right of the visual display (NEXT button command point)
- Red only on the left of the visual display (BACK button command point)
- Amber (BLACK button command point)

Releasing the Presenter Control button at any of these points will leave the system ready to receive a new command for that particular button on the handset.

Once the system is ready to receive a new command for the button you wish to re-program, press the key/s on the keyboard to simulate the command you require (e.g. press the letter 'w' to make the screen go to white), then press the Presenter Control button once more momentarily to store the new command.

Repeat this procedure to program each of the three handset buttons as required.

Special Requirements

Wireless Performance. The wireless RF system is designed to operate reliably in a typical enclosed AV venue environment at up to 75M. This can be reduced due to high levels of ambient RF interference so to ensure optimum performance please observe the following guidelines:

- Ensure the MicroCue² aerial is vertically orientated.
- Position the MicroCue² aerial within line-of-sight of the handsets, without large metallic objects in between as much as possible. The aerial can also be placed remote from the main unit using a 50 ohm BNC-BNC coaxial extension cable if required (max cable length: 4m).
- Avoid electrical/electronic interference by positioning the MicroCue² main unit away from equipment as much as possible.

PC Computer USB Interface. Suitable only for PC systems running a WINDOWS XP or later operating system. To ensure optimum performance, we can only recommend using the USB A-B type cable supplied.

Mac Computer USB Interface. When connecting to a Mac computer USB input, when the Mac keyboard assistant requests keyboard confirmation, simply 'cancel' this request and MicroCue will operate normally.

Radio Frequency System

MicroCue uses a proven RF system for all wireless applications.

Operating frequency:	434.075MHz (UK, Europe & USA)
Transmission method:	FM (Pure FSK)
Maximum transmit power:	10mW (EU) 11mV/m @3m (USA)

This frequency is open and licence exempt for UK, Europe and USA. Other countries should consult their respective authorities.

The system used is a coded transmission where the receivers are programmed to the transmitters which each have individual and unique codes. Nominal range of the transmitters is 300M open field or typically 75M in an enclosed venue.

Equipment Supplied

- 1 x MicroCue² main unit
- 1 x BNC adjustable angle aerial
- 1 x 3-button handset
- 2 x USB A-B cable

Optional Accessories

- 12V DC Power Supply (part no. PSU)
- Single button handset (part no. I2TX-1)
- Dual button handset (part no. I2TX-2)

For Technical Support or Sales Enquiries:

Interspace Industries Head Office:

+44 (0) 870 770 8088

Emergency Technical Support Hot Line:

+44 (0) 7976 385 046

Website:

www.interspaceind.com



28 High Street
Arlesey
Bedfordshire
SG15 6RA
UK

Tel: +44 (0) 870 770 8088

Fax: +44 (0) 870 770 8089

Email: moreinfo@interspaceind.com

www.interspaceind.com